

PRO 36R DRILLING MACHINE

A very powerful compact and lightweight machine for drilling in rails. Fast positioning, quick clamping and instant unlocking mechanisms make it easy to use and safe device.

PRO 36 R enables drilling in rails of any standard by means of 2pcs of optional rail profile templates and 1pcs of hole centre positioner, to be chosen by customers from a comprehensive range of auxiliary accessories dedicated to a variety of types of rails.

Pressure Coolant system including 5l bottle enables forced feeding of cooling medium in any drilling positions. It is ideal solution when gravitational feeding fails.

PRO 36R can also be ordered with Honda 4-stroke petrol motor as PRO 36RH.



Milling Capacity up to
36mm (1 7/16")

Electric
Motor

Custom made
positioners
and templates
available
on request



Max
Ø 36 mm
(1 7/16")



Max
Ø 16 mm
(5/8")

PRO 36R - Technical specification	
Spindle	Arbor 19 mm; 3/4" Weldon
Tool holder	
Milling Cutter (Core drill) Ø	12 - 36 mm (1/2" - 1 7/16")
Twist drill Ø	1,5 - 16 mm; 1/16" - 5/8"
Stroke	39 mm (1 9/16")
Max depth of cut	30 mm (1 3/16")
Voltage	240 VAC
Power consumption [W]	1260
Motor Power [W]	1260
Speeds [rpm]	250
Weight	15,0 kg (33 lbs 6 oz)
Product Code	WRT-0275-01-20-00-0

Standard shipping set:

- Rail Drilling Machine
- Metal Box
- Pressure Coolant 5l Bottle Assembly
- Set of Tools
- Instruction Manual (English)
- Standard shipping weight – 33,6kg (72 lbs 8 oz)

Rail profile templates and hole centre positioner are to be ordered, separately.



Upon customer's request any rail profile templates and hole centre positioners are subject to manufacture to meet any required rail standard.

Selected additional accessories:

- | | |
|---------------------|--|
| UST-0275-00-01-00-0 | S49 Rail Profile Template |
| UST-0275-00-02-00-0 | UIC 60 Rail Profile Template |
| WZR-0275-13-00-00-0 | S49 Hole Centre Positioner |
| WZR-0275-14-00-00-0 | UIC 60 Hole Centre Positioner |
| ZSP-0275-38-00-00-0 | Double-sided counter-sinking tool Ø 36mm (1-7/16") |

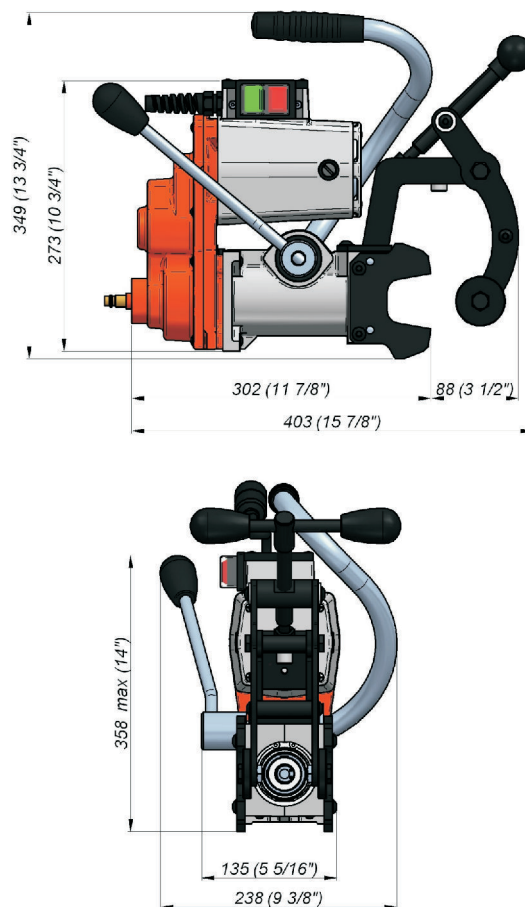

More information about accessories and spare parts is available at www.promotech.eu

PROMOTECH Sp. z o.o.
ul. Elewatorska 23/1, 15-620 BIAŁYSTOK, POLAND
tel. (+48 85) 678 34 05, fax (+48 85) 662-78-77
marketing@promotech.eu www.promotech.eu

Your local dealer:

