

PRO 40 DRILLING MACHINE

Lightweight, one speed and reliable machine which has been proven on many industrialized markets all over the world.

It can mill/cut up to 40 mm (1 9/16") and drill up to 13 mm (1/2").

PRO 40 is equipped with the latest generation of electromagnetic energy saving base (ESB) with magnetic field shape control system (MFSC) and magnetic power adhesion control module (MPAC), which measures adhesive force of electromagnetic base and prevents both the machine and the operator from work on workpieces which do not provide enough grip for the magnetic base.



1 speed gearbox

Magnetic Power Adhesion Control (MPAC)

Magnetic Field Shape Control (MFSC)

Energy Saving Base (ESB)



Max
Ø 40 mm
(1 9/16")



Max
Ø 13 mm
(1/2")



Max
Ø 40 mm
(1 9/16")

PRO 40 - Technical specifications:	
Motor Speed (under load)	440 [rpm]
Motor Power	1020 [W]
Weight	12,7 kg (27 lbs 6 oz)
Max milling capacity	Ø 40 mm (1-9/16")
Max drilling capacity	Ø 13mm (1/2")
Max countersinking	Ø 40 mm (1-9/16")
Stroke	124 mm (4-7/16")
Max depth of cut	51 mm (2")
Power supply	115V/60Hz or 230V 50/60 Hz
Power consumption	1100 [W]
MPAC (Magnetic Power Adhesion Control)	yes
MFSC (Magnetic Field Shape Control)	yes
ESB (Energy Saving Base)	yes
Magnetic clamping force	9.800 [N] (25mm, Ra=1,25)
Magnet Base Dimensions	84x168x 41,5 3 5/16 x 6 5/8 x 1 5/8 ["]
Min. Workpiece Thickness	6 mm (1/4")
Tool holder	19 mm (3/4") Weldon
Product Code 230V 50/60Hz	WRT-0291-10-20-00-3
Product Code 115V/60Hz	WRT-0291-10-10-00-3

Standard shipping set:

- Magnetic Base Drilling Machine
- Metal Box
- 19 mm (3/4") Weldon Arbor – for cooling through ring
- Swarf Shield/Cutter Guard
- Coolant Bottle Assembly
- Safety Chain
- Set of Tools
- Instruction Manual (English)
- Standard shipping weight – 18 kg (38 lbs 13 oz)

Selected additional accessories:

- UCW-0260-13-00-00-0 Quick Change 19 mm (3/4") Weldon Arbor for cooling through ring
- PDS-0110-00-00-00-0 DMP0250 Pipe Attachment
- PDS-0111-03-00-01-0 DMP0501 Pipe Attachment
- UKL-0399-11-00-00-0 Coolant Bottle Assembly
- LNC-0129-80-01-00-0 Safety Chain
- TLJ-0197-10-00-03-0 Drill Chuck Adapter x 1/2" - 20 UNF
- UCW-000059 Drilling Chuck 1,5-13 x 1/2" - 20 UNF

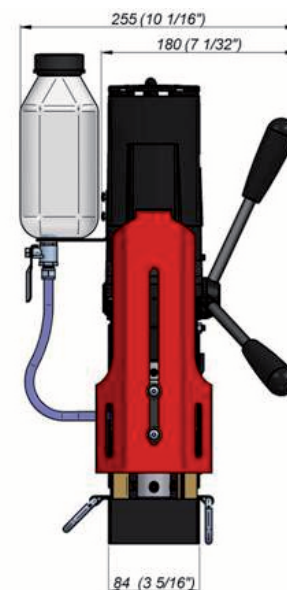
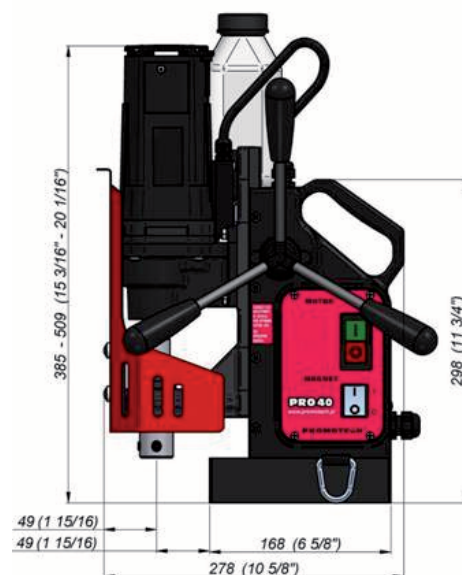

All information is subject to change without further notice version 11/2011

More information about accessories and spare parts is available at www.promotech.eu

PROMOTECH Sp. z o.o.
ul. Elewatorska 23/1, 15-620 BIAŁYSTOK, POLAND
tel. (+48 85) 678 34 05, fax (+48 85) 662-78-77
marketing@promotech.eu www.promotech.eu

Your local dealer:

