

# PRO 76T DRILLING MACHINE

<sup>®</sup>**PROMOTECH**

PRO 76T is the latest multifunction machine with Morse Taper No. 3 that can perform also tapping jobs thanks to the left and right rotations. The drill is equipped with motor overload protection system and continuous speed adjustment, which works in two speed ranges. Additionally, it has a state of the art Electronic Speed Stabilization System (ESSS), responsible for stabilizing motor's speed under varying loads on the spindle. Its precision and durability are significantly increased thanks to the one gearbox housing and slide.

Unique semi-automatic gib backlash adjustment (Promotech's patent pending) enables simple, fast and correct adjustments without any expert knowledge or experience. Replaceable spline at the end of armature shaft eliminates laborious and expensive armature maintenance. Compact design allows to drill very close to vertical surface.

PRO 76T is equipped with electromagnetic base featuring magnetic field shape control system (MFSC) and magnetic power adhesion control module (MPAC), which detects adhesive force of electromagnetic base and protects both the machine and the operator from work on too thin workpieces.

Standard shipping set of PRO 76T includes MT3 Arbor with 3" (19mm) Weldon Bore that accepts cutters up to 60mm (2-5/16") diameter. Optional MT3 Arbor with 1-1/4" (32mm) Weldon Bore for cutters of larger diameters is available.

PRO 76T can also be ordered with a swivel base as PRO 76T+.





<b>PRO 76T - Technical specification</b>	
Spindle	MT3
Tool holder	19 mm (3/4") Weldon
Milling Cutter (Core drill) Ø	max 76 mm (3")
Twist drill Ø	max 32 mm (1-1/4")
Countersinking Ø	max 63 mm (2-1/2")
Max Tap size	M24 (G 3/4")
Stroke	225 mm (8-7/8")
Max depth of cut	76 mm (3")
Voltage	115V/60Hz or 230V 50/60Hz
Power consumption [W]	1800
Motor Power [W]	1650
Speeds [rpm]	80 ÷ 160; 210 ÷ 420
Overload protection	yes
ESSS (Electronic Speed Stabilization System)	yes
Continuous Speed Adjustment	yes
MFSC (Magnetic Field Shape Control)	yes
Magnetic clamping force [N] (25mm, Ra=1,25)	19500
Magnet Base Dimensions	110 x 220 x 56 [mm] 4-5/16 x 8-11/16 x 2-3/16 ["]
MPAC (Magnetic Power Adhesion Control)	yes
Swivel base (PRO76T+)	± 15°; ± 15mm (± 9/16")
Min. Workpiece Thickness	10 mm (3/8")
Semi-automatic gib adjustment	yes
Weight	27 kg (58 lbs 4 oz)
Product Code 230V 50/60Hz	WRT-0473-10-20-00-0
Prod. Code 230V 50/60Hz w. swivel base	WRT-0473-10-20-00-1
Product Code 115V/60Hz	WRT-0473-10-10-00-0
Product Code 115V/60Hz w. swivel base	WRT-0473-10-10-00-1

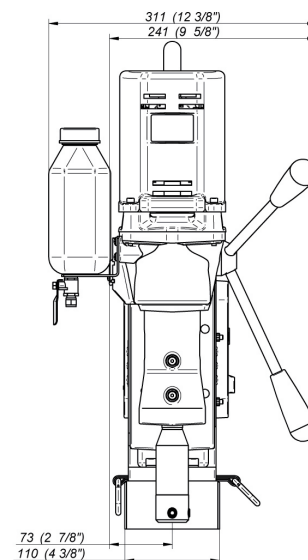
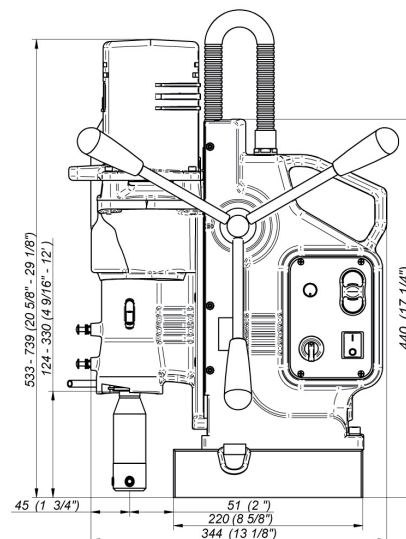

**Standard shipping set:**

- Magnetic Base Drilling Machine
- Metal Box
- MT3 Arbor with 19mm Bore - Through Spindle Continuous Cooling
- Swarf Shield/Cutter Guard
- Coolant Bottle Assembly, Safety Chain with Snap Hook, Set of Tools with Wedge
- Operator's Manual (English)
- Standard shipping weight – 40 kg (86 lbs 5 oz)

**Selected additional accessories:**

- UCW-0191-00-00-00-0 Through Spindle Continuous Cooling Arbor MT3-32 Weldon Bore
- UCW-0285-03-00-02-0 Quick Change Continuous Cooling Arbor MT3- 19 Weldon
- PDS-0111-03-00-01-0 DMP0501 Pipe Attachment
- UKL-0440-16-00-00-0 Pressure Coolant System 2l

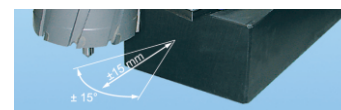

Swivel base in version PRO 76T+

All information is subject to change without further notice. 2012/06

